



# 36W Dimming Controller

LD-036-AW-01/02/03



## Description:

1. Dimming interface: 0-10V DIM/DALI dimming interface;
2. 0-10V analogue dimming, soft, fine and smooth, and the LED CRI won't be changed;
3. Dimming range 0-100%, LED dimming from 0.5%;
4. Wide current, multiple voltage amplitude, match a variety of lamp;
5. Power factor PF value  $\geq 0.92$ , overall efficiency  $\geq 0.83$ ;
6. Output short-circuit, over-current, over-temperature protection;
7. Suitable for indoor LED lighting environment.

## Features:

1. Input voltage: AC100-277V
2. Input frequency: 50/60Hz
3. Power factor PF: 0.92
4. Harmonic wave THD:  $\leq 13\%$  (120V),  $\leq 16\%$  (230V)
5. Efficiency:  $\geq 83\%$ , max. power of full load: 36W
6. Full load surge current of cold start: 16A
7. Output voltage with load: 24-40V, no-load output 42VDC
8. Output current:  $0.9A \pm 3\%$ , limited power 36W of constant voltage version
9. Working temperature: TC:  $70^{\circ}\text{C}$ , TA:  $-20^{\circ}\text{C} \sim 45^{\circ}\text{C}$
10. Storage temperature, humidity:  $-40^{\circ}\text{C} \sim +80^{\circ}\text{C}$ , 10-90%RH
11. Add dialing dimming/dialing switch output constant voltage performance

### Technical parameters :

Model	LD-036-AW-01	LD-036-AW-02	LD-036-AW-03
Version	36W (0-10V) constant current dimming version +dialing dimming	36W (0-10V) constant voltage dimming version + dialing switching voltage	36W Dali dimming plate
Input voltage	AC 100-277V	AC 100-277V	AC 100-277V
Output channel	Double channels	Double channels	Double channels
Output current/ voltage	CC:1A±3%,voltage with load: 24-40V,dialing switch constant current	CV:12V/24V/36V when dialing keys are full ON,that is 36V;when two of dialing keys are ON,that is 24V; when all dialing keys are OFF, that is 12V	CC:1.A±3% Voltage with load:24-40V
Output power	36W MAX	36W MAX	36W MAX
Protection grade	IP20	IP20	IP20
Match dialing function or not	dialing to adjust output constant current	Dialing to adjust output constant voltage	not
Dimension of dimming controller :L150*W40*H22mm		Dimension of outer carton: L271.5*W224*H173mm	
Packing dimension :L165*W55*H35mm		Packing qty. : 30 pieces	
Weight (gross weight):about 140 gram		Weight of whole carton: about 4.55 Kg	

### Product dimension(unit:mm):

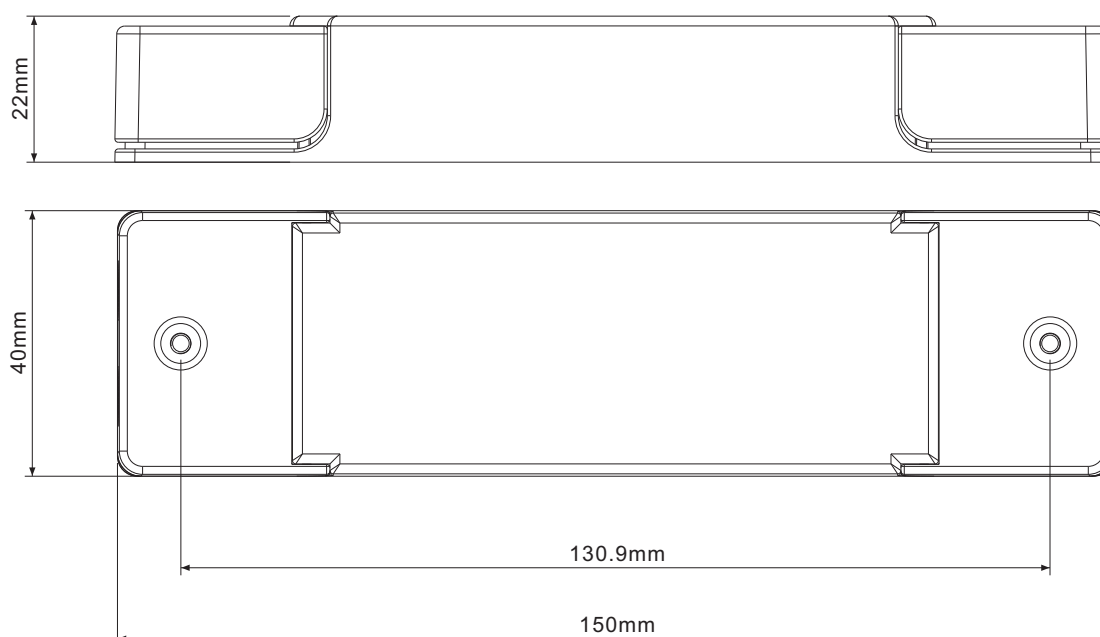



## Operation instructions of dialing switch function:

1. Dialing switch of 36W(0-10V) constant current dimming controller include three gears,if three gears are dialed to ON position, two channels output, each channel is constant current 0.5A; If one switch is dialed to OFF key, constant current of each circuit is 0.34A, independent from 0-10V dimming signal, and they were not in conflict.
2. Dialing switch of 36W(0-10V) constant voltage dimming controller include three gears.The no.2 dialing key is fixed on PCB,so the no.2 dialing key is invalid.If the no.1 or no.3 dialing key is dialed to OFF,then output constant voltage 24V; if 1-3 dialing keys are all dialed to OFF, output constant voltage is 12V. Output two ways are in fact one way,each of them can be used independently to max.power.

## Wiring diagram:

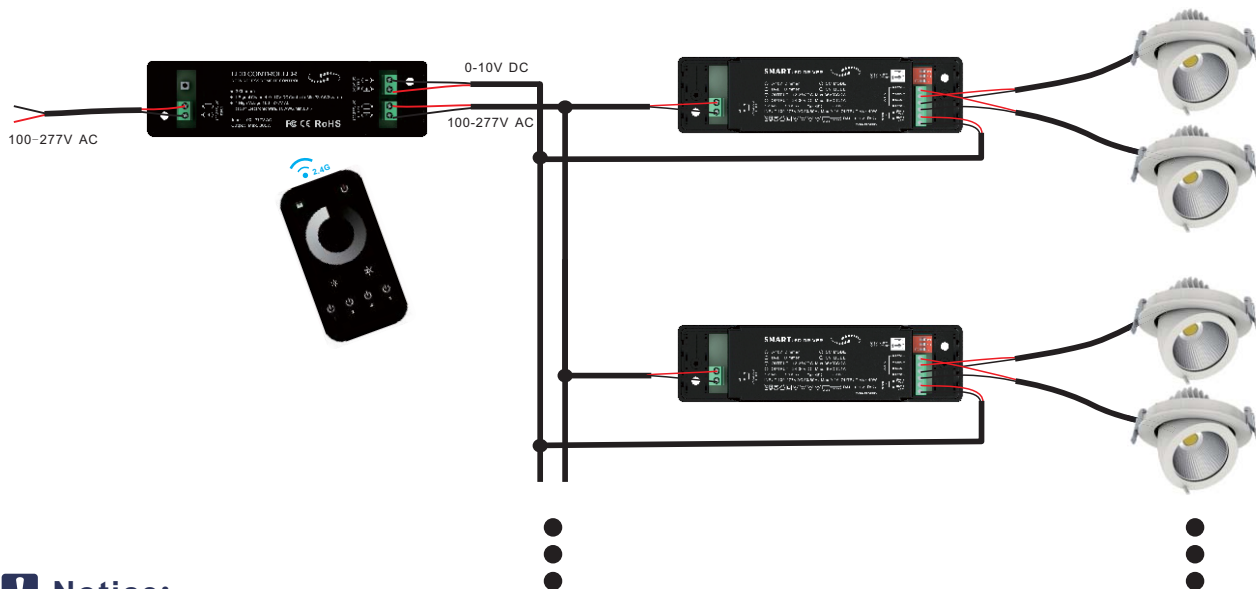

### ! Notice:

1. The controller must be installed by professionals;
2. When installing the controller, first power off, then connect LED products with controller, after doing the right, then power on it;
3. The product is non-waterproof, please install and use it in dry environment;
4. Good cooling conditions will extend lifetime of controller, please install the product in well-ventilated environment;
5. Ensure input voltage conform to voltage range requirement of product;
6. Wire size used must be sufficient load connected and make sure wires are securely connected;
7. Before power on, ensure all wires are correctly connected to avoid lamps damage caused by wrong wiring;
8. If a failure occurs, don't repair without permission, please contact the manufacturer.