



30W Promotional Flood Light

FL-030-AW-P



Description

Promotional Flood Light series light up the future of industry energy saving lighting in world. Flood light save energy at least 50% compared to high intensity discharge lamp, and it also can reduce maintenance cost and carbon emission. The flood light is combined with LED cutting-edge technology and unique optical design to reach the lighting effect equal to other traditional lighting source.

Features

1. Die-casting aluminum alloy lamp body, high strength toughened glass cover; solid and durable; corrosion-proof;
2. Excellent thermal management performance;
3. IP rating up to IP65;
4. Power factor ≥ 0.9 ;
5. Compared with traditional light, energy saving up to 60%;
6. High power COB, one piece is integrated 30W.
7. 30,000h lifetime.
8. Compliant with RoHS and CE standard.



Technical parameters

Model	CCT	Color	LED Type	LED Qty.	Light Output (±10%)	Power (±10%)	Voltage, frequency	Current	Beam angle	CRI	PF
FL-030-AW-W-P	5500-6500K	White	COB	1pcs	3130	30W	AC100-240V 50/60Hz	≤0.4A	100°	>70	≥0.9
FL-030-AW-NW-P	4000-4500K	Natural White		1pcs	3250	30W		≤0.4A	100°	>70	≥0.9
FL-030-AW-WW-P	2700-3200K	Warm White		1pcs	2660	30W		≤0.4A	100°	>70	≥0.9

Application

Mainly applied in outdoor flood lighting, building decoration, industry, sports center, outdoor stadium, port, parking lot, and road if there is street light distribution system.



Dimension (Unit:mm)

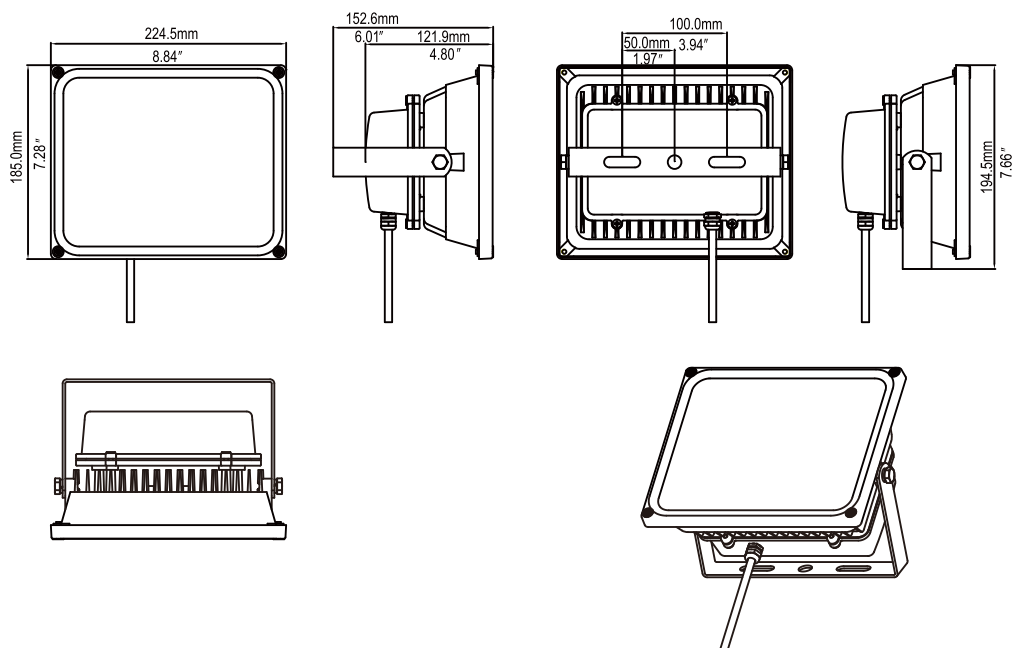



Installation

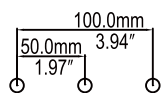

Hole dimension

Ceiling installation

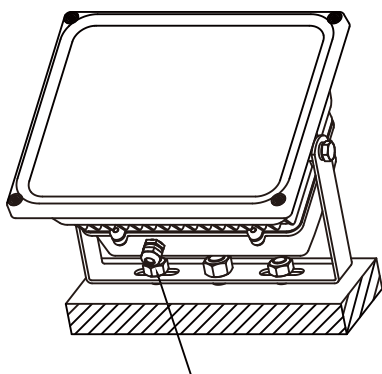
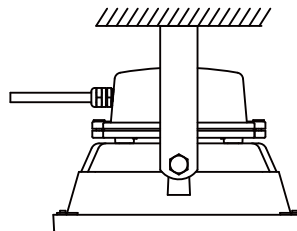

Fix the bracket on the installed surface.

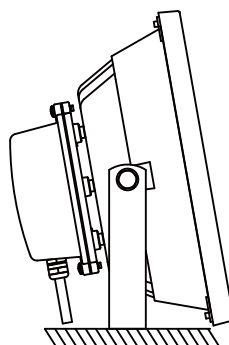

Seat type installation

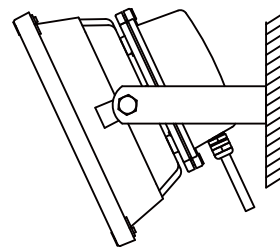

Wall type installation

Connection

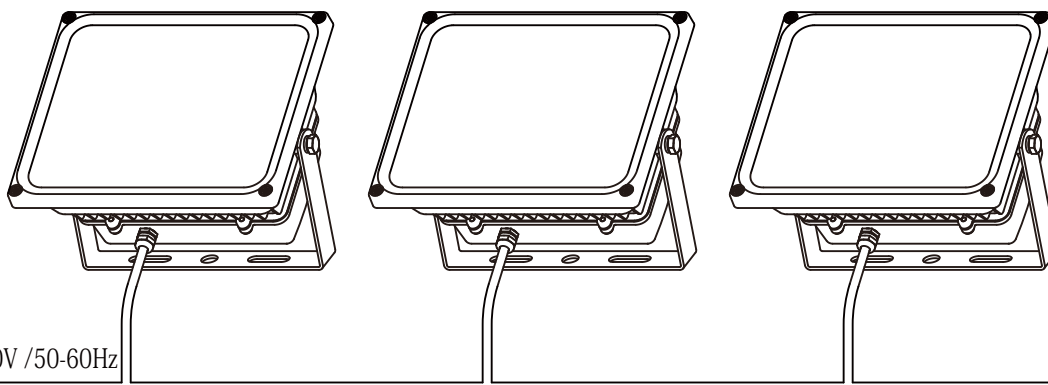

AC100-240V / 50-60Hz





Packing information

Net Weight:1.7KG Gross Weight:2.0KG
Packing box dimension: 254*152*228mm
Outer carton dimension: 520*320*480mm (8 pcs/carton)
Total weight: 17.0KG

Installation requirement

- 1.Please prepare bolts to install the light;
- 2.Power off before installation;
- 3.Make sure the installed surface can endure the weight of light, and fix the light on the installed surface securely(according to installation diagram);
- 4.Connect wire of light to power wire, insulate and seal the joint.

Notice

- 1.Please read the specification first, to make sure the service environment matches the condition in the specification before using.
- 2.Please confirm the applicable power supply before using.
- 3.Make sure the switch of product is off before connect to the power supply to prevent electric shock.
- 4.Operation against rules may damage your property even harm to your personal safety.
- 5.Dangerous high voltage, Non-professionals are not allowed to maintain the products.
- 6.If the exterior flexible cable or wire is damaged, it must exchange by the supplier, its agent or other similar qualified personnel to avoid dangers.
7. Operation environment: -20℃-45℃.